

Status: 04/2026



Print and
apply systems

HERMES QL
for linerless and
InNo-Liner materials

Materials in comparison

Adhesive label on liner

- Any kind of application by labels made of different materials
- Thermal transfer, direct thermal
- Label liner
- Costs associated with liner waste disposal
- Silicone coated liner
- Higher CO₂ emissions due to higher transport volumes and weights
- Stock space required to a greater extent
- 450 m of material with a roll diameter of 300 mm
- Downtimes and costs in greater numbers by roll changeovers
- Labels of the same length

Linerless

- Any kind of application onto packaging in industry and logistics
- Direct thermal
- No liner
- Eco-friendly, no costs associated with liner waste disposal
- Silicone coated label surface
- Less CO₂ emissions due to lower transport volumes and weights
- Less stock space required
- 800 m of material with a roll diameter of 300 mm
- Less downtimes and costs by fewer roll changeovers
- Labels of various lengths

InNo-Liner

- Application onto absorbent cardboard and paper surfaces, in particular shipping labels in logistics
- Direct thermal
- Thermal transfer upon request
- No liner
- Eco-friendly, no costs associated with liner waste disposal
- No silicone
- Less CO₂ emissions due to lower transport volumes and weights
- Less stock space required
- 800 m of material with a roll diameter of 300 mm
- Less downtimes and costs by fewer roll changeovers
- Labels of various lengths

Composition

Adhesive label on liner

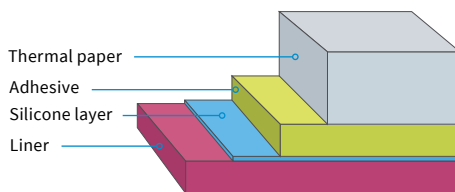

Linerless

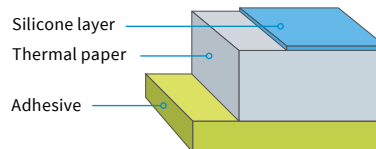

InNo-Liner

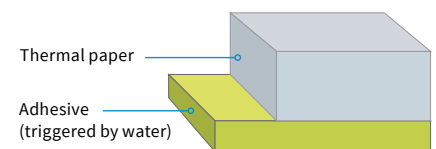

HERMES print and apply systems in comparison



	HERMES Q for self-adhesive labels	HERMES QL	
		for linerless	for InNo-Liner
Materials	Self-adhesive labels on a liner	Continuous linerless materials	Continuous InNo-Liner materials
Adhesive	self-adhesive	self-adhesive	water-activated
Print methods	Thermal transfer Direct thermal	Direct thermal	Direct thermal Thermal transfer upon request
Print widths	as wide as 168 mm	as wide as 108.4 mm 168 mm upon request	as wide as 108.4 mm 168 mm upon request
Print speeds	as fast as 300 mm/s	as fast as 250 mm/s	as fast as 250 mm/s
Print rollers	Synthetic rubber or silicone coating	Anti-stick coating	Silicone coating
Print resolution	200 dpi 300 dpi 600 dpi	200 dpi 300 dpi	200 dpi 300 dpi
Roll diameters if chassis dimensions are identical	205 mm	300 mm max.	300 mm max.
Length of materials if chassis dimensions are identical	180 m	800 m	800 m
Orientations of assembly	vertical, horizontal	vertical, horizontal	vertical
Margin stop	necessary	N/A	necessary
Applicators	all HQ applicators	all HQ applicators	HQ 4034 applicator
Common features	Printer dimensions, firmware, user interface, interfaces, applicator connectivity, assembly assistance		

Other SQUIX linerless label printers

see www.cab.de/en/linerless



Label printers		SQUIX Linerless 4.3		SQUIX Linerless 6.3	
Print resolution	dpi	203	300	203	300
Print speed	mm/s max.	250	250	250	250
Print width	mm max.	104	108.4	168	162.6

HERMES QL label printers

A base unit fits for both linerless and InNo-Liner materials. Print rollers for linerless materials have anti-stick coating. Standard DRS4 print rollers are recommended for InNo-Liner.

Disposal of liner materials and associated costs are eliminated.

Approximately 40 percent more labels fit onto a roll, which in turn is easier in transport. System downtimes are reduced due to fewer roll changeovers.

By activating a saving feature, material is cut automatically subsequent to a final print line and an offset.

Full compatibility: Features, dimensions and installation correspond to the tried and tested HERMES Q systems.

A large extent of applicators and assembly assistances can be used in original, HERMES Q standard and QL linerless printers be switched back and forth easily.

Cycle rates correspond to HERMES Q applicators, added by about 50 milliseconds delay time for cutting the linerless labels.



1 Rugged metal chassis

It is the base for component assembly. Made of cast aluminum

2 Operation panel

Intuitive and easy configuration with the help of self-explanatory symbols on the user interface

3 Peripheral port

An applicator can be plugged easily and quickly.

4 Applicators

Pivotable for maintenance or material changeover

5 Cutter

for separating continuous materials

6 Unlocking lever

for pivoting and removing a cutter

7 Deflection roller

Axially adjustable for materials running straight

8 Label unwinder

A pendulum arm and an integral brake keep a label web under constant tension.



Cutter

It separates printed labels even to different heights.

Blade and cutter bar each have anti-stick coating.

The entire cutter can be quickly and easily removed and reinstalled without additional tools in cases of cleaning, changing a print roller or maintaining a print head.

Print head

It is designed for direct thermal printing.

Major data such as operational performance, maximum operation temperature and heating are kept in memory. The data can be read at the premise.

Linerless print roller

DRL4 print roller, designed for continuous linerless materials, anti-stick-coating

InNo-Liner print roller

DRS4 print roller, designed for continuous InNo-Liner material, silicone coating

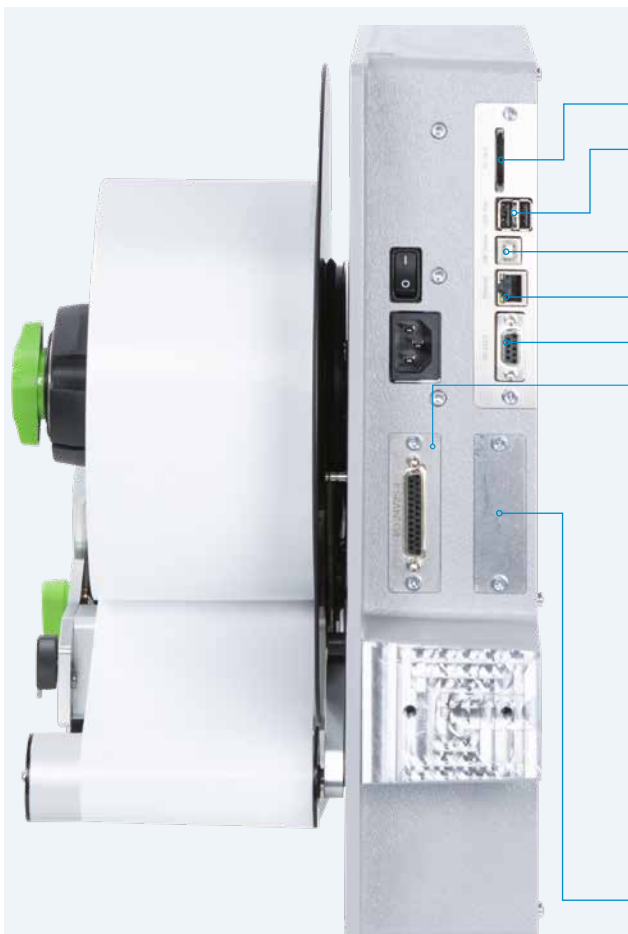

Interfaces

- 1 Port for plugging a **SD memory card**
- 2 **2 USB hosts** for plugging a service key, an USB stick, a keyboard, a barcode scanner, an USB WLAN stick, a warning light, an external operation panel
- 3 **USB 2.0 Hi-Speed device** for plugging a PC
- 4 **Ethernet 10/100 Mbit/s**
- 5 **RS232C** 1,200 to 230,400 baud/8 bit
- 6 **Digital I/O**
SUB-D socket connector, 25 pins, compliant to IEC/EN 61131-2, type 1+3
The inputs and outputs are galvanically isolated and protect from reverse polarity. The outputs are also short-circuit-proof.

PNP inputs

Start printing / applying
Print first label
Reprint
Delete print job
Label removed
Stop printing / applying
Label feed
Pause
Reset

PNP, NPN outputs

Unit ready
Print data available
Initial / upper end position
Paper feed ON
Label peel-off
Labeling / lower end position
Prior warning to label web ending
Label web ending
Collective error

Option







- 7 **Port for additional interfaces**

Operation panel

Self-explanatory symbols are on display. The device can thus be operated intuitively and settings be configured easily.

- 1 **LED:** Power ON
- 2 **Status bar:** data reception, record data stream, pre-warning to a ribbon ending, SD memory card / USB memory stick plugged in, WLAN, Ethernet, USB slave, time
- 3 **Printer status:** ready, pause, number of labels printed in a print job, label in transfer position, awaiting external start signal
- 4 **USB slot** to connect a service key or a memory stick, to transfer data to the IFFS memory

5 Operation

-  Printing and applying labels in individual steps
-  Jump to menu
-  Reprint the latest label
-  Interrupt and continue a print job
-  Stop and delete all print jobs
-  Label feed



Setup options



Print parameters

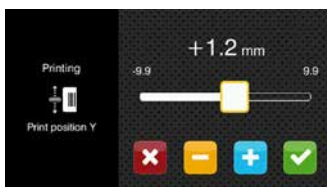

Print offset Y

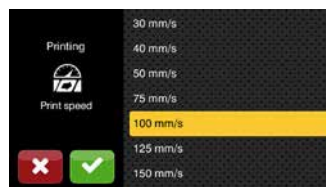

Print speeds

Landscape or portrait display, depending from the orientation of assembly



Printer rotated by 90°



Video tutorials

External operation panel

If the operation panel of a printer cannot be accessed, an additional external one can be plugged.

Same functionality as on the printer

Landscape or portrait mode

Operability as desired on the external operation panel or on the printer

Printer connectivity: USB 2.0 Hi-Speed device

- 1 **LED:** Power ON
- 2 **USB port** to plug a service key or a memory stick, to transfer data to the IFFS memory
- 3 **Connecting USB cable** for power supply
cab provides specified cables. Lengths are 1.8 m to 16 m.



HERMES QL options

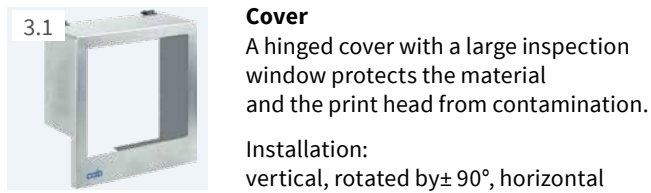

Cover

A hinged cover with a large inspection window protects the material and the print head from contamination.

Installation:
vertical, rotated by $\pm 90^\circ$, horizontal

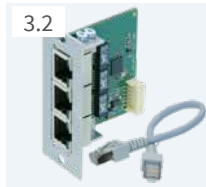

2 port Ethernet switch 10/100 Mbit/s
for plugging another terminal device in a joint network. Signals are looped through.

InNo-Liner version only



DRS4, DRS6 print rollers

for continuous InNo-Liner material



Margin stop 300

Guiding a material and securing a continuous roll

HERMES QL accessories

2.1		SD memory card
2.2		USB stick
2.3		USB WLAN stick 2.4 GHz 802.11b/g/n Hotspot mode or infrastructure mode
2.4		USB WLAN stick with a rod antenna for extended range of operation 2.4 GHz 802.11b/g/n + 5 GHz 802.11a/n/ac Hotspot mode or infrastructure mode
2.6		Product sensor, 3 pins to be attached to a front side applicator, a vacuum belt applicator or an air jet box. Labels are triggered to be applied as soon as a product has been detached, e.g. on a conveyor belt.
2.7		Product sensor, 25 pins Labels are triggered to be applied as soon as a product has been detached, e.g. on a conveyor belt.
2.8		I/O interface plug, SUB-D, 25 pins All control signals are plugged to the I/O interface
2.9		Warning light States are indicated in addition to the information on the display of a printer. Red Collective error Yellow Prior warning to a label material ending Green Unit ready USB cable (1 m) for connecting to HERMES QL Assembly materials are provided only for vertical printer installation. 1 Chassis assembly 2 Bracket assembly

2.10		External operation panel If the operation panel of a printer cannot be accessed, an additional external one can be plugged. Same functionality as on a printer Landscape mode or portrait mode Operability as targeted, either on an external panel or on a printer
		USB 2.0 Hi-Speed device for connecting to a printer cab provides specified USB cables for power supply. Lengths 1.8 m to 16 m
2.11		Label selection - I/O box A maximum of 16 labels per box can be selected from a memory card by a superior control unit, such as a PLC.
2.12		TR2 hand switch for plugging to an I/O interface
2.13		Foot switch for plugging to an I/O interface
2.14		Connecting RS232-C cable 9/9 pins, 3 m

HERMES QL wear parts



DRL4, DRL6 print rollers

for continuous linerless material



DRS4, DRS6 print rollers

for continuous InNo-Liner material

Technical data

■ standard □ option

Label printer	Type	HERMES QL4.3		HERMES QL6.3 upon request	
Print method		Direct thermal			
Print resolution	dpi	200	300	200	300
Print speed	mm/s max.	300	300	250	250
Print width	mm max.	104	108.4	168	162.6
Print length	mm max.	13,500	9,000	9,000	4,000
Direction to which labels are dispensed		L = to the left, R = to the right			
Print distant to locating edge	mm	1			
Material					
Continuous linerless material wound onto a roll					
Width	mm	50 - 118		50 - 178	
Height ¹	mm	30 - 456		30 - 456	
Thickness	µm max.	84		84	
Unwinder	Roll outside diameter	mm max.	300	300	
	core diameter	mm	76	76	
	Winding	outside		outside	
Printer dimensions, weights					
Width x Height x Depth	mm	260 x 400 x 400		320 x 400 x 400	
Weight	kg approx.	13		19	
cover included	kg approx.	15.5		21.5	
Material control					
both end positions on pendulum arm		■			
Electronics					
Processor, 32 bit clock rate	MHz	800			
RAM	MB	256			
IFFS	MB	50			
Port for plugging a SD memory card (SDHC, SDXC)		■			
Battery for indicating time and date, real-time clock		■			
Data kept in memory (e.g. serial numbers) when power turns off		■			
Interfaces					
RS232-C 1,200 to 230,400 baud / 8 bit		■			
USB 2.0 Hi-Speed device for plugging a PC		■			
Ethernet 10/100 Mbit/s IPv4 and IPv6		LPD, RawIP printing, SOAP web service, OPC UA, WebDAV, DHCP, HTTP/HTTPS, FTP/FTPS, TIME, NTP, Zeroconf, SNMP, SMTP, VNC			
2 USB hosts on the operation panel, 2 USB hosts on the back of a unit		Service key, USB stick, USB WLAN stick, USB WLAN stick with a rod antenna, keyboard, barcode scanner, warning light, external operation panel			
USB host, 24 VDC, for peripheral / applicator plugging		■			
Digital I/O interface providing 10 inputs and 11 outputs		■			
Operating data					
Voltage		100-240 VAC, 50/60 Hz, PFC			
Consumption of power		< 10 W in standby / 100 W in typical operation / max. 200 W			
Temperature / humidity	Operation	+5 - 40°C / 10 - 85 %, not condensing			
	Stock	0 - 60°C / 20 - 85 %, not condensing			
	Transport	-25 - 60°C / 20 - 85 %, not condensing			
Approvals		CE, FCC Class A, ICES-3			
	in preparation	UKCA, cULus, CB			
	upon request	CCC, BSMI, KC-Mark, Mexico Reg., RCM			
Operation panel					
Color LCD touchscreen	Diagonal	"	4.3		
	Resolution Width x Height	px	272 x 480		

¹ Heights according to a tamp-on pad in use resp. length of a vacuum belt on an applicator

Scopes of delivery, design and technical specifications correspond to the date of the printing. Subject to change. The data provided in the catalog do not represent any warranty or guarantee.

Technical data

■ standard □ option

Setup options		
Print Labels Peel off Apply Interfaces Error	Region: - Language - Country - Keyboard - Time zone Time Display: - Brightness - Power saving mode - Orientation Interpreter	
Status bar		
Receive data Record data stream SD memory card plugged USB stick plugged	WLAN Ethernet USB slave Time	
Controls		
Labels - prior warning - material provided - material ending	Peripheral error	
Print head Voltage Temperature open	Cutter - pivoted - no final position	
Test routines		
System diagnostics	upon startup, detection of print head included	
Information display, test printout, analysis	Status printout Fonts list List of units WLAN status Print data recorded on memory card	Test grid Label profile List of events Monitor mode
Status reports	- Printout of print durations, running hours, etc. - Status of a unit requested by software command - Display of errors related to a network, barcode or peripheral device, links missing, etc.	
Fonts		
Integral	5 bitmap fonts: 12 x 12 dots 16 x 16 dots 16 x 32 dots OCR-A OCR-B	7 vector fonts: AR Heiti Medium GB-Mono CG Triumvirate Condensed Bold Garuda HanWangHeiLight Monospace 821 Swiss 721, Bold
For memory	TrueType	
Sets of characters	Windows-1250 to -1257 DOS 437, 737, 775, 850, 852, 857, 862, 864, 866, 869 EBCDIC 500 ISO 8859-1 to -10 and -13 to -16 WinOEM 720 UTF-8 DEC MCS	MacRoman KOI8-R
	Western European Eastern European Chinese, simplified Chinese, traditional Thai	Cyrillic Greek Latin Hebrew Arabic
Bitmap	1 mm to 3 mm wide and high Zoom factors 2 to 10 0°, 90°, 180°, 270° orientations	
Vector / TrueType	0.9 mm to 128 mm wide and high Continuous zoom 360° orientation in steps of 1°	
Styles	bold, italic, underlined, outline, inverse - depending on the font type	
Character spacing	proportional or monospace	
Graphics		
Elements	lines, arrows, rectangles, circles, ellipses - filled and gradient	
Formats	PCX, IMG, BMP, TIF, MAC, GIF, PNG	

Codes		
1D barcodes, linear	Code 39, Code 93 Code 39 Full ASCII Code 128 A, B, C EAN 8, 13 EAN/UCC 128/GS1-128 EAN/UPC Appendix 2 EAN/UPC Appendix 5 FIM HIBC	Interleaved 2/5 Ident and routing code of Deutsche Post Codabar JAN 8, 13 MSI Plessey Postnet RSS 14 UPC A, E, E0
2D codes, stacked codes	DataMatrix DataMatrix Rectangle Extension QR code Micro QR code rMQR code GS1 QR code GS1 DataMatrix GS1 Digital Link (QR and DataMatrix) PDF 417 Micro PDF 417 UPS MaxiCode GS1 DataBar Aztec Codablock F Dotcode RSS 14 truncated, limited, stacked, omni-directional	All codes may vary in height, modular width and ratio. 0°, 90°, 180°, 270° orientations Feasibility of check digits, plain text printouts and start/stop coding depending on the type of code
Software		
Label software	cablabel S3 Lite cablabel S3 Viewer cablabel S3 Pro cablabel S3 Print	■ ■ □ □
Running also with	CODESOFT Loftware Spectrum NiceLabel BarTender	in preparation
Stand-alone operation		■
Windows printer drivers certified WHQL for	Windows 10 Windows 11	Server 2016 Server 2019 Server 2022
Apple printer drivers	Mac OS X 10.6 or any later release	
Linux printer drivers	CUPS 1.2 or any later release	
Programming	JScript printer language abc Basic Compiler ZPL II (Datastream be tested in advance)	■ ■ □
Integration	SAP Database Connector	■ ■
Administration	Printer control Configuration on the Intranet and Internet	■ ■

Free and Open Source software in cab products:
www.cab.de/opensource

cablabel S3 software

Design, print, administrate

cablabel S3 opens up the full potential of cab devices. Creating a label is the first step. cablabel S3 adapts to requirements easily using a modular design. Plug-ins like the JScript Viewer support native JScript programming, as well as other features. The designer user interface and the JScript code synchronize in real time. The Database Connector and other special features can be integrated, so are barcode verifiers.



For further information see
www.cab.de/en/cablabel

Stand-alone printing

A printer can select and print labels even when the system is disconnected from a host.

Labels are designed using software such as cablabel S3 or a text editor on a PC. Label formats, texts, graphics and data taken from a database are transferred to a memory card, a USB memory stick or the internal IFFS memory.

Only variable data are sent to the printer using a keyboard, a barcode scanner, scale or another host system and/or are recalled from a host by the Database Connector and printed.



OPC UA

The latest cab printers are ready to interact with machines and components of different manufacturers in industrial plants.

An OPC UA server and a client are part of the firmware.

The server enables a printer be configured and controlled. Dynamic print data can be edited using a defined programming interface.

The integral client enables reading data fields from other machines ready for OPC UA, as well as transferring data to a label. No additional software is needed.



Printer control

Drivers



cab provides drivers to control a printer with software other than cablabel S3.



Free download on www.cab.de/en/support



Programming



JScript

cab printers embed JScript language. Download free manual on www.cab.de/en/programming



abc Basic Compiler

Integral to the firmware, abc in addition to JScript enables advanced programming before data are edited for printout. For example, external printer languages can be replaced without intervening in a print job in progress. Data may be imported as well from other systems such as scales, barcode scanners or PLC.

Connecting to SAP®

Labels can be printed from SAP¹⁾ on cab devices and systems. There are various methods:

- Printing with SAPscript
- Printing with SmartForms
- Printing with Adobe Interactive Forms

See instructions in detail on www.cab.de/en/sap

¹⁾ SAP and associated logos are trademarks or registered trademarks of SAP SE.

Printer administration



Configuration on the Intranet / Internet

Integral HTTP / FTP servers enable a printer be controlled or configured, firmware be updated and memory cards be administrated using standard applications such as a web browser or a FTP client.

Administrators and operators on behalf of SNMP / SMTP are notified of states, alerts and errors by email or SNMP datagrams. Time and date are synchronized by a time server.

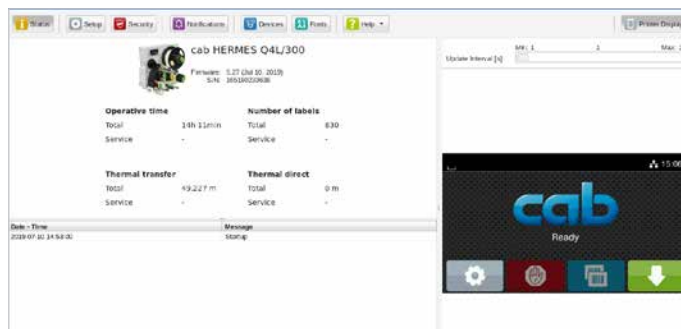

Database Connector

Printers in a network may access data from a ODBC / OLEDB database and print it on labels. Data can be rewritten to a database while print jobs are in progress.



Linerless / InNo-Liner applicators



Automatic labeling

HERMES HQ applicators are a further development of the proven HERMES applicators, fully compatible, adding extra functions. Existing applications can continue without limitations.

Easy to configure

The applicator can be fully set on the printer operation panel, configurations be stored and called up. Automatic calibration features speed up the setup.

Process control

Detailed statistical values are provided, so are sophisticated error messages. Constant control enables response right away in events of errors.

Updates

Applicator firmware can be updated on the printer operation panel or the printer's web server. New features and specific solutions can therefore be tested right away and distributed in the field.

1 Long product life

by a precise and low-wear linear guide

2 Products of variable heights

Labels can be applied on different heights using a stroke cylinder. Its standard lengths are 200, 300, 400 and 600 mm.

3 Protective chassis

is a standard to protect the cylinder and the guide. It can be provided adapted to the product jig on a labeling workstation.

4 Highly reliable processes

Support air and intake air can be defined, so can stroke speed. Sensor control

5 Label application

in real time. Small or large labels, 30 to 456 mm high and 50 to 105 mm wide, can be processed using an applicator

6 Pivotal applicator

The print mechanics can be accessed quickly and easily in case of maintenance or if materials have to be replaced.

Options:

Pressure-reducing valve

It reduces the pressure exerted by the stroke cylinder to a product.

Pressure-reduced applicator

It has been designed for manual workstations missing a protective cover. The cylinder diameter is reduced to 12 mm. To prevent from injuries, a safety valve limits compressed air to a maximum of 4.8 bar.



HQ 4024, HQ 4026 stroke applicators

- As much as 80 percent savings of compressed air
- Labels of variable heights applied using one tamp-on pad

Even labels of different height are applied in real time onto packages.

Labels are reliably tamped spring-mounted onto inclined surfaces. Pads are available in three models for label heights 40 mm to 100 mm, 40 mm to 150 mm, or 40 mm to 210 mm. Labels 50 mm to 105 mm wide or 50 mm to 150 mm wide can be processed.

Labels are sucked by an electrically driven fan. Only the stroke cylinder requires compressed air.



Accessory

5.14 Unit to regulate compressed air

Option

5.18 Pressure-reduced applicator

Stroke applicator		HQ 4024 L/R-200	HQ 4024 L/R-300	HQ 4024 L/R-400	HQ 4024 L/R-600	HQ 4026 L/R-200	HQ 4026 L/R-300	HQ 4026 L/R-400	HQ 4026 L/R-600
Distance of a package to the bottom of a unit	mm max.	135	235	335	535	135	235	335	535
Package height	mm	variable							
Alternation in heights of packages	mm max.	100	200	300	500	100	200	300	500
Direction from which labels are applied onto a package		from the top, from below, from the side			from the top	from the top, from below, from the side			from the top
State of a package at the moment a label is applied		at rest							
Control	Sensor 1	initial / upper end position							
	Sensor 2	label on tamp-on pad							
	Sensor 3	labeling / lower end position							
Consumption of power	W max.	30							
Compressed air	bar	4.5							
Cycle rate ¹⁾	labels/min approx.	30							

¹⁾ calculated using a stroke of 100 mm below a unit, labels 40 mm high, a print speed of 100 mm/s

			Tamp-on pad, spring-mounted	
Transfer module			4024 - 3000	4026 - 3000
Label width	HQ 4024	mm	50 - 105	
	HQ 4026	mm	50 - 150	
Label height	HQ 4024, HQ 4026	100 mm	40 - 100	
	HQ 4024, HQ 4026	150 mm	40 - 150	
	HQ 4024, HQ 4026	210 mm	40 - 210	

HQ 4034, HQ 4036* stroke applicators for InNo-Liner

*upon request

Various label sizes can be facilitated by a single roll-on pad, linerless materials included.

Even labels of different heights are applied in real time onto packages.

Labels are reliably rolled spring-mounted onto inclined surfaces. Pads are available in three models for label heights 40 mm to 100 mm, 40 mm to 150 mm, or 40 mm to 210 mm. Labels 50 mm to 105 mm wide or 50 mm to 150 mm wide can be processed.

Labels are sucked by a fan without the use of air support.

A micro vaporizator is directly attached next to the cutter. Nozzles trigger the material's adhesive layer by wetting. In detail, atomized spray is applied from a 6-liter container of distilled water, mixed with air. For labels measuring 100 x 100 mm, water consumption is 0.2 liters per 1000 labels.



Accessory

5.14 Unit to regulate compressed air

Option

5.18 Pressure-reduced applicator



Stroke applicator		HQ 4034 L/R-200	HQ 4034 L/R-300	HQ 4034 L/R-400	HQ 4034 L/R-600	HQ 4036 L/R-200	HQ 4036 L/R-300	HQ 4036 L/R-400	HQ 4036 L/R-600	
Distance of a package to the bottom of a unit	mm max.	135	235	335	535	135	235	335	535	
Package height	mm	variable								
Alternation in heights of packages	mm max.	100	200	300	500	100	200	300	500	
Direction from which labels are applied onto a package		from the top, from the side								
State of a package at the moment a label is applied		in motion								
products of equal heights		at rest (labels tamped on) /in motion (labels rolled on)								
products of different heights										
Control	Sensor 1	initial / upper end position								
	Sensor 2	label on tamp-on pad								
	Sensor 3	labeling / lower end position								
Consumption of power	W max.	30								
Compressed air	bar	4.5								
Cycle rate ¹⁾	labels/min approx.	25								
Micro vaporizator		MSK 2L/R			MSK 4L/R			MSK 6L/R		
Quantity of nozzles		3			6			8		
Material width	mm	60			105			150		

¹⁾ calculated using a stroke of 100 mm below a unit, labels 40 mm high, a print speed of 100 mm/s

Transfer module	Roll-on pad, spring-mounted		Roll-on pad, transverse and spring-mounted	
	4034 - 4000	4036 - 4000	4034 - 7000	4036 - 7000
Direction from which labels are applied onto a package	from the top, in direction of transport		from the top and from the side, transverse the direction of transport	
Label width	HQ 4034	mm	50 - 105	
	HQ 4036	mm	50 - 150	
Label height	HQ 4034, HQ 4036	100 mm	40 - 100	
	HQ 4034, HQ 4036	150 mm	40 - 150	
	HQ 4034, HQ 4036	210 mm	40 - 210	

A product remains at rest at the moment a label is applied. On further transport, the label is rolled onto the product using rollers below the pad.

HQ 3014, HQ 3016 front side applicators

Labels are applied in real time preferably from the top or from the side onto the front or back of packages in motion.

The pad locates in front of the peel-off plate. Printed labels are taken over and set onto packages by a rotary cylinder. A sensor detects each package and triggers the pivot arm / pad to its initial position.

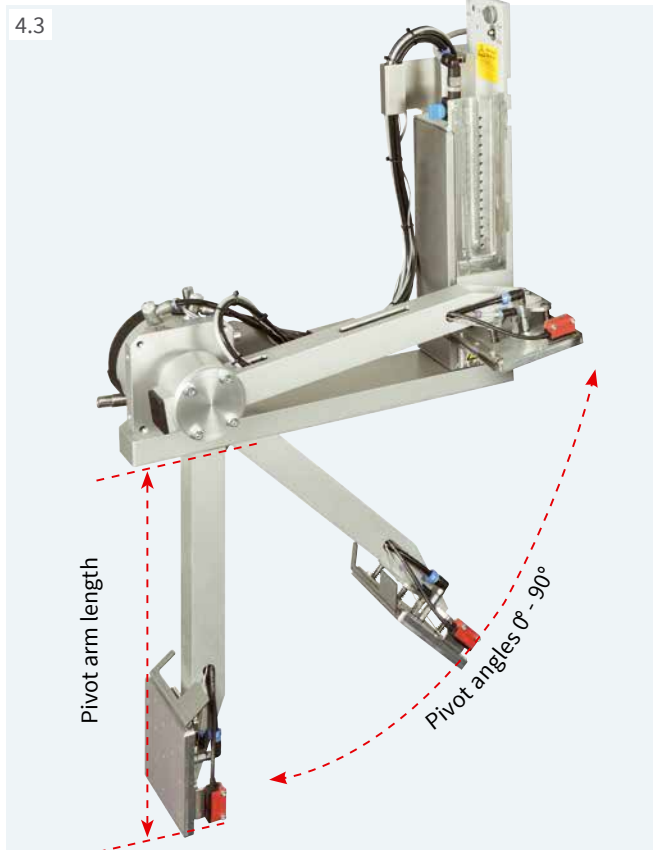
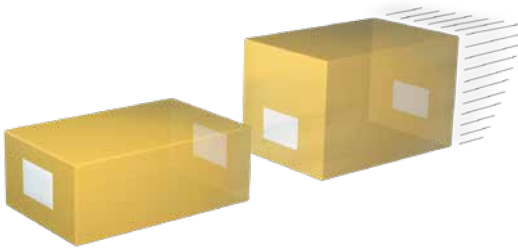

Accessories

- 5.13 **Blow tube**
- 5.14 **Unit to regulate compressed air**

Front side applicator	HQ 3014 L/R-200	HQ 3014 L/R-300	HQ 3014 L/R-400	HQ 3014 L/R-600	HQ 3016 L/R-200	HQ 3016 L/R-300	HQ 3016 L/R-400	HQ 3016 L/R-600
State of a package	at rest							
at the moment a label is applied	in motion							
Direction from which labels are applied	from the top, from the side, from the front, from the back							
Package height	variable							
Pivot arm length ¹⁾	200	300	400	600	200	300	400	600
Pivot angle	0-90°							
Weight of applicator	9	9.5	10.5	11.5	9.5	10	11	12
packaging excluded kg								
Consumption of power	W max.							
Compressed air	bar							
Cycle rate ²⁾	labels/min approx.							
	15							

¹⁾ Pivot arm length defines the targeted spot of a label (lower margin) set 90° below a HERMES QL footprint.

²⁾ calculated using a pivot arm 200 mm long, labels 100 mm high, a print speed of 100 mm/s



Tamp-on pad
Labels are precisely tamped onto plane, even recessed, surfaces.



Tamp-on pad, spring-mounted
Labels are applied onto surfaces inclined as much as 15° using a spring-mounted vacuum plate. Height within a label area may vary by 10 mm.



Blow-on pad
Labels are blown onto the surfaces of packages by a blast of air, bridging a distance of 5 mm to 10 mm.

Transfer module			Tamp-on pad	Tamp-on pad, spring-mounted	Blow-on pad
			3014, 3016 L/R 1100 B x H	3014, 3016 L/R 3100 B x H	3014 L/R 2100 B x H
Label width	HQ 3014	mm	25 - 114	80 - 114	25 - 114
	HQ 3016	mm	25 - 174	80 - 174	-
Label height	HQ 3014	mm	8 - 250	80 - 250	10 - 100
	HQ 3016	mm	25 - 250	80 - 250	25 - 100

HQ 4614 stroke blow applicators

Labels are applied in real time from all sides onto packages of various heights in motion.

The pad locates in front of the peel-off plate. Printed labels are taken over. A sensor triggers the stroke cylinder direct the pad to a target spot approximately 10 mm above a package. The length of the stroke cylinder defines how far packages may differ in heights.

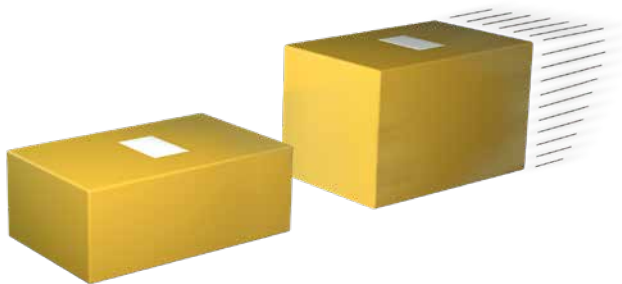

Accessories

5.13 **Blow tube**

5.14 **Unit to regulate compressed air**



Stroke blow applicator		HQ 4614 L/R-200	HQ 4614 L/R-300	HQ 4614 L/R-400
Distance of a package to the bottom of a unit	mm max.	140	240	340
Package height	variable	■		
Direction from which labels are applied		from the top, from below, from the side		
State of a package at the moment a label is applied	at rest	■	■	■
	in motion	■	■	■
Weight of applicator	packaging excluded kg	not specified	5.5	6.5
Consumption of power	W max.		15	
Compressed air	bar		4.5	
Cycle rate ¹⁾	labels/min approx.		25	

¹⁾ calculated using a stroke of 100 mm below a unit, labels 100 mm high, a print speed of 100 mm/s

Blow-on pad

Labels are blown onto the surfaces of packages by a blast of air, bridging a distance of 5 mm to 10 mm.



Blow-on pad			4614L/R-2100 W x H
Label width	HQ 4614	mm	20 - 114
Label height	HQ 4614	mm	20 - 100

HQ 4014, HQ 4016 stroke applicators

Labels are applied in real time preferably onto packages.
 The type of pad defines whether a package has to be at rest or may be in motion at the time a label is applied.
 Labels can be applied from all sides.

The pad locates in front of the peel-off plate. Printed labels are taken over and set onto packages by a stroke cylinder.
 A sensor detects each package and triggers the pad to its initial position.

The length of the stroke cylinder defines the maximum distance of a package to the peel-off plate.



Accessories

- 5.13 **Blow tube**
- 5.14 **Unit to regulate compressed air**

Options

- 5.17 **Pressure-reducing valve**
- 5.18 **Pressure-reduced applicator**



Stroke applicator	HQ 4014L/R-200	HQ 4014L/R-300	HQ 4014L/R-400	HQ 4014L/R-600	HQ 4016L/R-200	HQ 4016L/R-300	HQ 4016L/R-400	HQ 4016L/R-600		
Package height	variable									
State of a package at the moment a label is applied	at rest									
Direction from which labels are applied	from the top, from below, from the side			from the top, from below	from the top, from below, from the side			from the top, from below		
Distance of a package to the bottom of a unit	mm max.	130	230	330	530	130	230	330	530	
Weight of applicator	packaging excluded	kg	5	5	7	9	5	5.5	7.5	9.5
Consumption of power	W max.								15	
Compressed air	bar								4.5	
Cycle rate ¹⁾	labels/min approx.								25	

¹⁾ calculated using a stroke of 100 mm below a unit, labels 40 mm high, a print speed of 100 mm/s



Tamp-on pad
 Labels are precisely tamped onto plane, even recessed, surfaces.



Universal pad
 Labels are tamped onto flat surfaces. Drilled vacuum holes (in gaps of 5 mm) for sucking labels are covered by sliding foil and can be opened according to a label size using a perforation tool. Delivery includes two extra foils for replacement.



Tamp-on pad, spring-mounted
 Labels are applied onto surfaces inclined as much as 15° using a spring-mounted vacuum plate. Height within a label area may vary by 10 mm.



Universal pad, spring-mounted
 Labels are applied onto surfaces inclined as much as 15° using a spring-mounted vacuum plate. Height within a label area may vary by 10 mm. Drilled vacuum holes (in gaps of 5 mm) for sucking labels are covered by sliding foil and can be opened according to a label size using a perforation tool. Delivery includes two extra foils for replacement.

Transfer module			Tamp-on pad	Universal pad	Tamp-on pad, spring-mounted	Universal pad, spring-mounted
			4014, 4016 L/R 11 F B x H	4014 L/R 1100	4014, 4016 L/R 3100 B x H	4014 L/R 3100
Label width	HQ 4014	mm	20 - 114	75 / 90	80 - 114	105 / 105
	HQ 4016	mm	50 - 174	-	80 - 174	-
Label height	HQ 4014	mm	20 - 210	60 / 90	80 - 210	102 / 152
	HQ 4016	mm	25 - 210	-	80 - 210	-
Depth of a pad immersing F ²⁾		mm max.	140	-	-	-

²⁾ On the cover HERMES QL4.3 cut-out dimension F standard 60 mm, optional 100 mm, upon request up to 120 mm
 On the cover HERMES QL6.3 cut-out dimension F standard 25 mm, upon request up to 120 mm

HQ 4014, HQ 4016 stroke applicators

Labels are applied in real time preferably onto packages.
 The type of pad defines whether a package has to be at rest or may be in motion at the time a label is applied.
 Labels can be applied from all sides.

The pad locates in front of the peel-off plate. Printed labels are taken over and set onto packages by a stroke cylinder.
 A sensor detects each package and triggers the pad to its initial position.

The length of the stroke cylinder defines the maximum distance of a package to the peel-off plate.

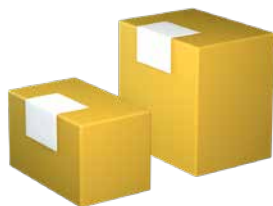

Accessories

- 5.13 **Blow tube**
- 5.14 **Unit to regulate compressed air**

Options

- 5.17 **Pressure-reducing valve**
- 5.18 **Pressure-reduced applicator**



Stroke applicator		HQ 4014L/R-200	HQ 4014L/R-300	HQ 4014L/R-400	HQ 4014L/R-600	HQ 4016L/R-200	HQ 4016L/R-300	HQ 4016L/R-400	HQ 4016L/R-600
State of a package at the moment a label is applied	at rest	Blow-on pad, corner-wrap pad							
	in motion	Blow-on pad, roll-on pad							
Direction from which labels are applied	from the top	Blow-on pad, roll-on pad, corner-wrap pad							
	from below	Blow-on pad, roll-on pad							
	from the side	Blow-on pad, roll-on pad		-		Blow-on pad, roll-on pad		-	
Distance of a package to the bottom of a unit	Blow-on pad	mm max.	140	240	340	540	-	-	-
	Roll-on pad	mm max.	160	260	360	560	160	260	360
	Corner-wrap pad	mm max.	100	200	300	500	-	-	-
Package height	uniform	Blow-on pad							
	variable	Roll-on pad, corner-wrap pad							
Weight of applicator	packaging excluded	kg	5	5	7	9	5.5	5.5	7.5
Consumption of power		W max.	15						
Compressed air		bar	4.5						
Cycle rate ¹⁾		labels/min approx.	25						

¹⁾ calculated using a stroke of 100 mm below a unit, labels 100 mm high, a print speed of 100 mm/s



Blow-on pad

Labels are blown onto sensitive surfaces or packages in motion by a blast of air. Distances of 5 mm to 10 mm to of a package are set by a stop on the stroke cylinder.



Roll-on pad

Labels are rolled onto plane packages in motion.



Corner-wrap pad

Labels are applied to two adjacent sides of a package. The pad applies the first half of a label onto the top of the package. The second half is then rolled on.

Transfer module			Blow-on pad	Roll-on pad	Corner-wrap pad
			4014 L/R 2100 B x H	4014, 4016 L/R 4100 B x H	4014 L/R 5100 B x H
Label width	HQ 4014	mm	20 - 114	25 - 114	20 - 114
	HQ 4016	mm	upon request	50 - 174	-
Label height	HQ 4014	mm	20 - 100	80 - 250	60 - 210
	HQ 4016	mm	upon request	80 - 250	-

5314, 5316 vacuum belt applicators

Labels can be applied in real time from all sides onto plane packages in motion.

The applicator locates in front of the peel-off plate. Printed labels are guided along a vacuum belt to a target point. Applications onto packagings are triggered by an external signal.



Vacuum belt applicator			5314-2	5314-3	5314-4	5316-2	5316-3	5316-4
Label application			onto plane surfaces					
Direction to which labels are provided			left and right					
Label width	HERMES QL4.3	mm	20 - 114	20 - 114	20 - 114	-	-	-
	HERMES QL6.3	mm	-	-	-	46 - 174	46 - 174	46 - 174
Label height		mm	60 - 256	60 - 356	60 - 456	60 - 256	60 - 356	60 - 456
State of a package at the moment a label is applied		in motion	■					
Direction from which labels are applied			from the top, from below, from the side					
Package height		uniform	■					
Package speed		m/s max.	0.5					
Gap between packages		m at least	0.5					
Vacuum belt speed ¹⁾		mm/s	100 - 500					
Weight of applicator		packaging excluded kg	7	7	7	8	8	8
Consumption of power		W max.	90					
Cycle rate ²⁾		labels/min max.	30					
Distance of a label to the belt, when applying from the side		mm	Y = 20					

¹⁾ The speed of a package must be at least as high as the speed of the vacuum belt.

²⁾ calculated using labels 100 mm high and a print speed of 250 mm/s

5414, 5416 vacuum belt applicators

Labels can be applied from the top or from the side onto cylindric packages in motion. Corner-wrap applications are as well possible.

The applicator locates in front of the peel-off plate. Printed labels are guided along a vacuum belt to a target point. Applications onto packagings are triggered by an external signal.



Vacuum belt applicator			5414-3	5414-4	5416-3	5416-4
Label application			onto cylindric surfaces, corner-wrap			
Direction to which labels are provided			left and right			
Label width	HERMES QL4.3	mm	20 - 114	20 - 114	-	-
	HERMES QL6.3	mm	-	-	46 - 174	46 - 174
Label height		mm	80 - 356	80 - 456	80 - 356	80 - 456
State of a package at the moment a label is applied		in motion	■			
Direction from which labels are applied			from the top, from the side			
Package height	uniform		■			
	variable		■			
Package speed		m/s max.	0.3			
Gap between packages		m at least	0.5			
Steadiness at application level			F ¹⁾ = 30 N			
Corner-wrap label application		mm max.	X = 160			
Vacuum belt speed ²⁾		mm/s	100 - 300			
Weight of applicator	packaging excluded	kg	7	7	8.5	8.5
Consumption of power			W max. 90			
Cycle rate ³⁾			labels/min max. 15			
Distance of a label to the belt, when applying from the side			mm Y = 20			

¹⁾ F = force required for pivoting vacuum belt

²⁾ The speed of a package must be at least as high as the speed of the vacuum belt.

³⁾ calculated using labels 100 mm high and a print speed of 250 mm/s

HQ 6114 air jet box

Labels are applied onto packages in motion or at rest. Each label is sucked by a fan and blown off by an aligned blast of air. Subject to the size of a label, distances as wide as 200 mm can be bridged between a package and the peel-off plate.

1 Template

for covering all vacuum and blow-off drillings next to a label

Pre-scored in an 8 mm x 8 mm pattern, they can be easily adapted to the size of a label. All areas next to a label are covered when inserting between a vacuum block and slide rails. Delivery includes five templates.

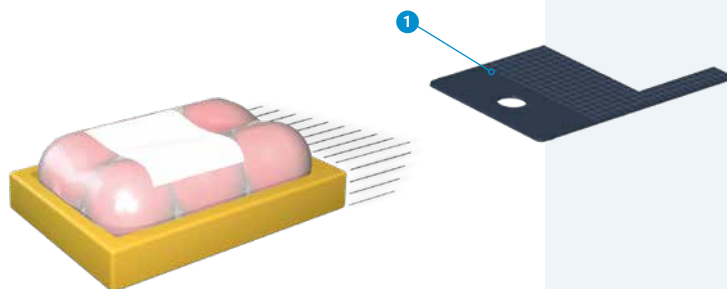

4.8



Accessories

5.13 **Blow tube**

5.16 **Unit to regulate compressed air, providing a shut-off valve**

Air jet box			HQ 6114 L/R
Label width	HERMES QL4.3	mm	50-114 (smaller sizes upon request)
Label height		mm	50-125 (smaller sizes upon request)
State of a package		at rest	■
at the moment a label is applied		in motion	■
Direction from which labels are applied			from the top, from below, from the side
Package height		variable	■
Distance of a package to peel-off plate		mm max.	200
Weight of air jet box		packaging excluded kg	4
Consumption of power		W max.	90
Compressed air		bar	4.5
Cycle rate ¹⁾		labels/min max.	60

¹⁾ calculated using labels 50 mm high, a print speed of 250 mm/s, a blast of air lasting 100 ms, with packages located 100 mm to the peel-off plate

Continuous linerless materials

RL540 linerless

Packaging of all kinds in industry and logistics;
2 mm adhesive-free area along margins

P98 linerless

Packaging of all kinds in industry and logistics;
full-area adhesive

InNo-Liner IDL

Absorbent cardboard and paper surfaces,
such as shipping labels in logistics;
full-area adhesive

All materials are free from bisphenols
and suit for use in food business.



Material	RL540 linerless	P98 linerless	InNo-Liner IDL
Type	Direct thermal paper, white	Direct thermal paper, white	Direct thermal paper, white
Thickness	approx. 80 µm	approx. 82 µm	84 µm
Adhesive	self-adhesive acrylic	self-adhesive acrylic	water-activated
Initial grip	moderate	very strong	moderate
Food recommendation	not specified	BfR XIV or FDA 21 CFR 175.105	BfR XXXVI
Application temperature	from 5°C	from 5°C	10°C - 30°C
Service			
- Temperature	-10°C - 100°C	-20°C - 80°C	-20°C - 50°C
- humidity, not condensing	not specified	not specified	20% - 85%
Shelf life	12 months	24 months	24 months ¹⁾
- Temperature	23°C ± 5°C	20°C ± 5°C	20°C - 25°C
- humidity, not condensing	50% ± 10%	45% ± 5%	40% - 50%
Application	indoor	indoor	indoor
Print speed	mm/s max. 200	250	250
Material length	m 700	800	800
Roll diameter	mm 300	300	300
Core diameter	mm 76	76	76
Winding	outside	outside	outside

¹⁾ by date of manufacture under FINAT-defined storage conditions

Designation	Item no.	Material width mm	Material length m	PU1 Cardboard	PU2 Pallet
RL540 continuous linerless material / 58 mm x 700 m	upon request	58	700	2 rolls	64 rolls
RL540 continuous linerless material / 80 mm x 700 m	upon request	80	700		
RL540 continuous linerless material / 105 mm x 700 m	5780402	105	700		
P98 continuous linerless material / 60 mm x 800 m	upon request	60	800	2 rolls	64 rolls
P98 continuous linerless material / 80 mm x 800 m	upon request	80	800		
P98 continuous linerless material / 100 mm x 800 m	5780502	100	800		
P98 continuous linerless material / 148 mm x 800 m	upon request	148	800		
InNo-Liner IDL continuous linerless material / 51 mm x 800 m	upon request	51	800	2 rolls	64 rolls
InNo-Liner IDL continuous linerless material / 80 mm x 800 m	upon request	80	800		
InNo-Liner IDL continuous linerless material / 100 mm x 800 m	5780302	100	800		
InNo-Liner IDL continuous linerless material / 148 mm x 800 m	upon request	148	800		

Further widths upon request

Applicator accessories

5.13



Blow tubes

to provide support air. To assist label transfer, the label is blown from below to the pad.

Provided for 2" or 4" labeling applications, 6" available upon request

5.14



Unit to regulate compressed air

4.5 bar default setting

Provided in a left-hand or right-hand design

Delivery includes a fine filter, a pressure control valve with a display, a hose to connect to an applicator's compressed air input and material to assemble the unit to a chassis or a bracket.

5.16



Unit to regulate compressed air, providing a shut-off valve to vent a hose line subsequent to the unit

Provided in a left-hand or right-hand design

Applicator options

5.17



Pressure-reducing valve

It reduces the pressure exerted by the stroke cylinder to an item.

5.18



Pressure-reduced applicator

It has been designed for manual workstations missing a protective cover. The cylinder diameter is reduced to 12 mm. To prevent from injuries, a safety valve limits compressed air to a maximum of 4.8 bar.

For HQ applicators, this option is available as standard only for the 300 mm stroke length

HERMES QL assembly assistance

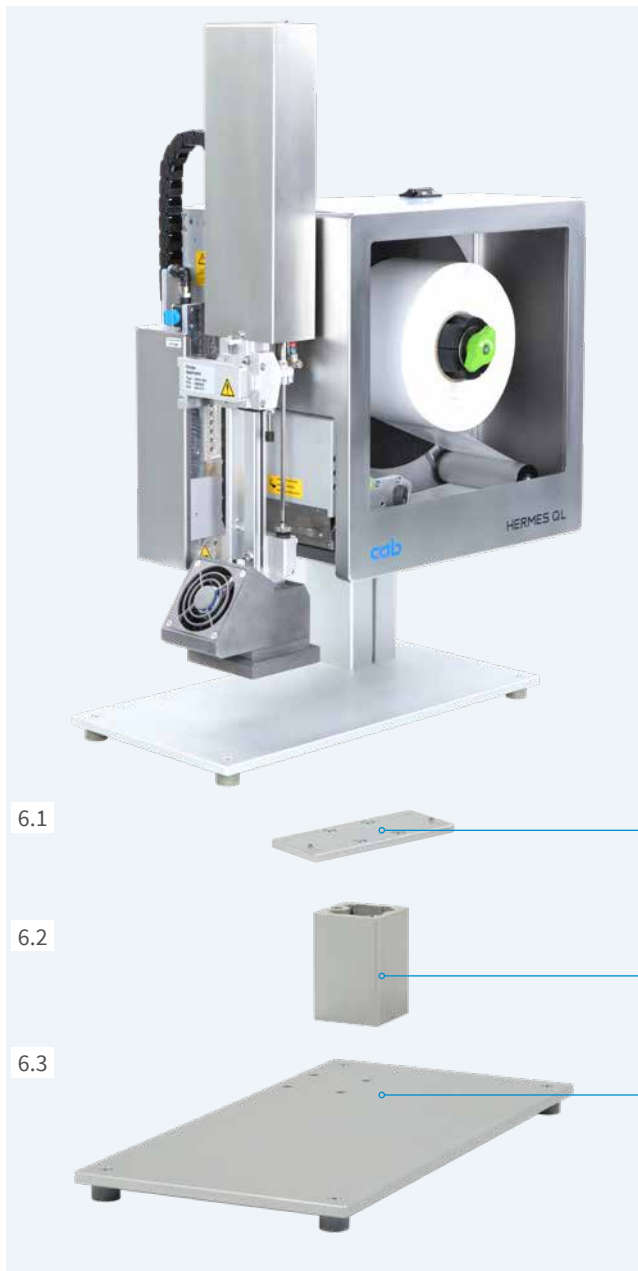

Mount

for desktop setup or installation into production lines
 Provided in a left-hand or right-hand design

The size can be individually adapted to any operation.

6.1



1 Adapter plate

for fixing a print and apply system.

Alternatively, a system can be assembled directly into a production line, using the adapter plate and a profile.

6.2



2 Profile

Aluminum square

Standard lengths 40, 80, 120, 160, 200, 300 mm

6.3



3 Base plate

for fixing a product jig

Standard dimensions 500 mm x 255 mm

6.4



4 Base plate, xy stop and product sensor included

Standard dimensions 500 mm x 255 mm

HERMES QL assembly assistance



Bracket
to assemble to a floor stand

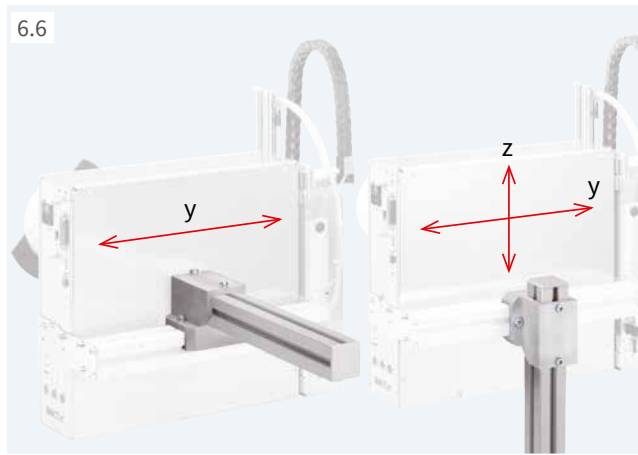

Clamped joint designed for a 50 mm x 50 mm profile
to move in horizontal or vertical direction

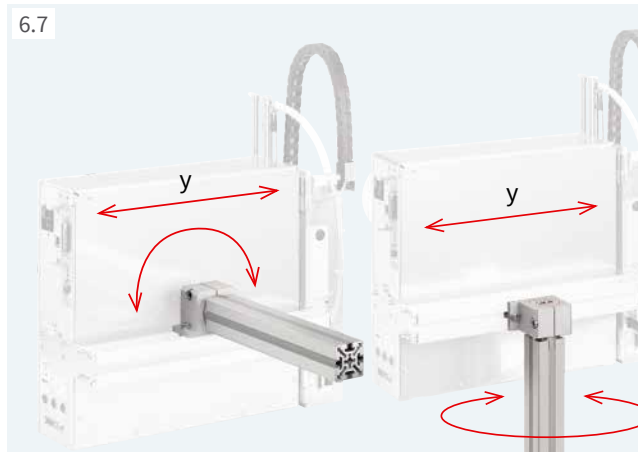

Flanged joint designed for a 50 mm x 50 mm profile
to move in horizontal direction or rotate around an axis

HERMES QL installation

Applying labels in direction of transport
from the top from the side

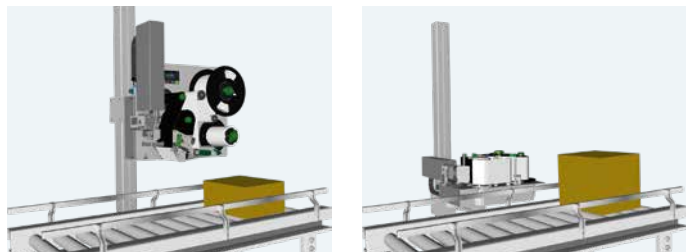

Applying labels transverse the direction of transport
from the top from the side

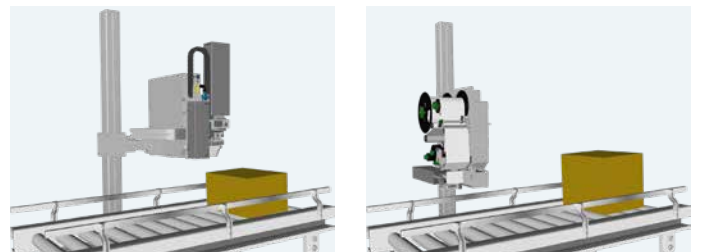

HERMES QL floor stands

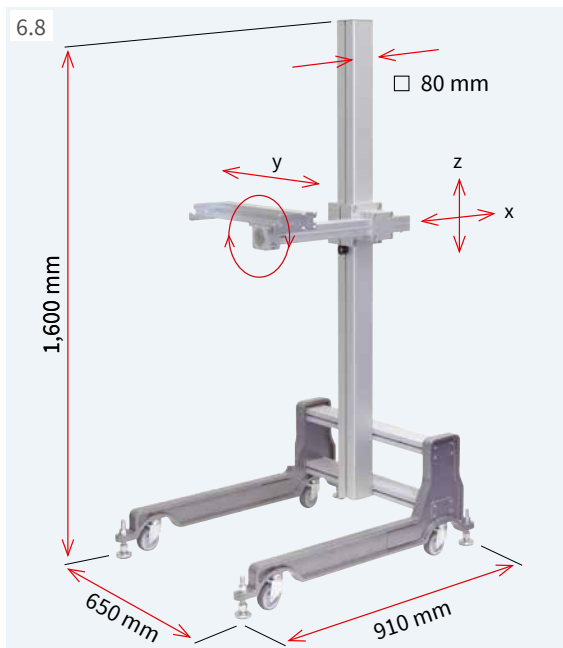

HERMES QL can be installed into a production line and aligned in three axes to an item to label. Pivoting is also possible.

1601 floor stand

It benefits when operating in different production lines. Mobility is provided. At the place of operation, the floor stand can be fixed with the help of feet to adjust.

Floor stand		1601
Base frame		castors, leveling feet
Adjustment in height and depth		screw clamping
Load at offset 500 mm	kg max.	50
Weight	kg	36

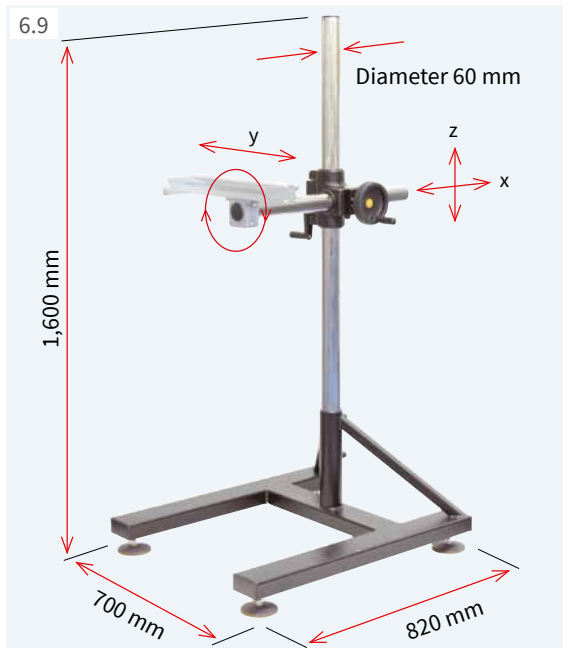

1602 floor stand

It benefits if positions to apply labels are changing frequently in terms of heights and depths. HERMES QL can be aligned in directions x and z to a product using a toothed rack.

Floor stand		1602
Base frame		leveling feet
Adjustment in height in depth		toothed rack / crank toothed rack / handwheel
Load at offset 500 mm	kg max.	50
Weight	kg	38

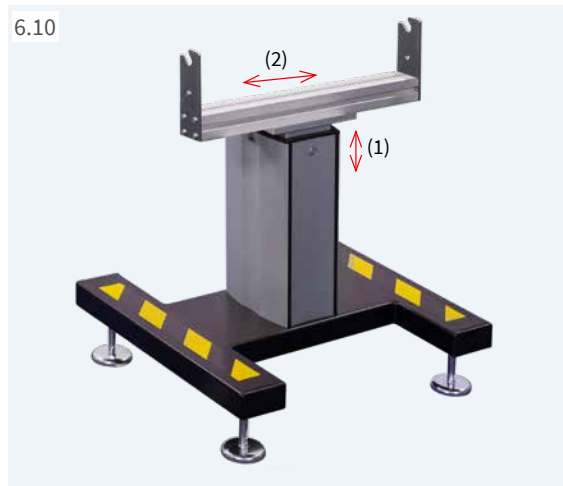

1201 floor stand

for installing HERMES QL horizontally into a production line. Heights can be adjusted continuous using an integral spindle.

A unit to regulate compressed air can be assembled to the bracket, so can a warning light.

Floor stand		1201
Leveling feet	adjustable by mm	± 15
Load	kg max.	75
(1) Lower label margin to floor ¹⁾	mm	720 - 960
(2) Depth along direction of transport	mm	± 100
Weight	kg approx.	40

¹⁾ further dimensions upon request

HERMES QL delivery program

QL linerless and InNo-Liner label printers

Labels provided to the left

Pos.	Item no.	Designation
1.1		6012002 HERMES QL4.3L/200 label printer
		6012000 HERMES QL4.3L/300 label printer
	6012003	HERMES QL6.3L/200 label printer
		6012001 HERMES QL6.3L/300 label printer

xxxxxxx.250 if HERMES QL provides options

Labels provided to the right

Pos.	Item no.	Designation
1.1		6012012 HERMES QL4.3R/200 label printer
		6012010 HERMES QL4.3R/300 label printer
	6012013	HERMES QL6.3R/200 label printer
		6012111 HERMES QL6.3R/300 label printer

xxxxxxx.250 if HERMES QL provides options

Scope of delivery
HERMES QL label printer Type E+F power cable, 1.8 m Connecting USB cable, 1.8 m Assembly instructions DE / EN



Provided online	
 https://setup.cab.de/en	Assembly instructions DE / EN / FR Configuration manuals DE / EN / FR Service manuals DE / EN Spare parts lists DE / EN Programming manual EN Windows printer drivers certified WHQL for Windows 10 Server 2016 Windows 11 Server 2019 Server 2022 Server 2025 Apple Mac OS X printer drivers DE / EN / FR Linux printer drivers DE / EN / FR cablabel S3 Lite software cablabel S3 Viewer Database Connector



See current data also on the Internet:
www.cab.de/en/hermesql













Scopes of delivery, designs and technical data correspond to the date of this publication. They are subject to change. Catalogue data do not represent any warranty or guarantee.

Options

Pos.	Item no.	Designation
3.1		6012130.xxx Cover 4L
		6012140.xxx Cover 4R
3.2		upon request Cover 6L
		upon request Cover 6R
3.2	6010520.xxx	2 port Ethernet Switch 10/100 Mbit/s
3.3		5954985.xxx DRS4 print roller
		5954979.xxx DRS6 print roller
3.4	5962367.xxx	Margin stop 300





xxx - .250 assembled to a printer
.001 separate delivery

Accessories

Pos.	Item no.	Designation
2.1	 5977370	SD memory card
2.2	 5977730	USB stick
2.3	 5978912	USB WLAN stick 2.4 GHz 802.11b/g/n
2.4	 5977731	USB WLAN stick with a rod antenna 2.4 GHz 802.11b/g/n + 5 GHz a/n/ac
2.6	 5970071	Product sensor, 3 pins
2.7	 5964300	Product sensor, 25 pins
2.8	 5917651	I/O interface plug, SUB-D, 25 pins
2.9	 6010560	Warning light
2.10		6010186 External operation panel
		5907718.001 Connecting USB cable, 1.8 m
		5907730.001 Connecting USB cable, 3 m
		5907750.001 Connecting USB cable, 5 m
		5907760.001 Connecting USB cable, 11 m
5907765.001 Connecting USB cable, 16 m		
2.11	 5948205	Label selection - I/O box
2.12	 5955710	TR2 hand switch
2.13	 5955711	Foot switch
2.14	 5550818	Connecting RS232-C cable, 9/9 pins, 3 m

HERMES QL delivery program

Wear parts

Pos.	Item no.	Designation	dpi
	5977382.001	Print head 4.3	200
	5977383.001	Print head 4.3	300
	5977386.001	Print head 6.3	200
	5977387.001	Print head 6.3	300
	6012025.001	DRL4 print roller	
	6012026.001	DRL6 print roller	
	5954985.001	DRS4 print roller	
	5954979.001	DRS6 print roller	
	6012095.001	Blade L	
	6012096.001	Blade R	
	6012078.001	Cutter bar	

Label software

Pos.	Part no.	Designation
	Bundle	cablabel S3 Lite (download on cab.de/en)
	5588001	cablabel S3 Pro, 1 WS
	5588100	cablabel S3 Pro, 5 WS
	5588101	cablabel S3 Pro, 10 WS
	5588150	cablabel S3 Pro, 1 additional licence
	5588151	cablabel S3 Pro, 4 additional licences
	5588152	cablabel S3 Pro, 9 additional licences
	5588002	cablabel S3 Print, 1 WS
	5588105	cablabel S3 Print, 5 WS
	5588106	cablabel S3 Print, 10 WS
5588155	cablabel S3 Print, 1 additional licence	
5588156	cablabel S3 Print, 4 additional licences	
5588157	cablabel S3 Print, 9 additional licences	
	in preparation	cablabel S3 Print Server
7.10	9008486	Programming manual EN, printed copy

Assembly assistance

Pos.	Item no.	Designation
6.1	5965940	Adapter plate
6.2	5958365	Profile 40
	5965929	Profile 80
	5971136	Profile 120
	5987701	Profile 160
	5987702	Profile 200
5987703	Profile 300	
6.3	5961203	Base plate 500 x 255 mm
6.4	5989277	Base plate, xy stop and product sensor included
6.5	5955685	Bracket
6.6	8914443	Clamped joint designed for a 50 mm x 50 mm profile
6.7	8914444	Flanged joint designed for a 50 mm x 50 mm profile

Floor stands







Pos.	Item no.	Designation
6.8	5970113	1601 floor stand
6.9	5970112	1602 floor stand
6.10	5972515	1201 floor stand

User languages

Language	Assembly instructions	Operation panel	Windows driver	Service manual	cablabel S3
European Union					
Bulgarian		X	X		X
Danish	X	X	X		
German	X	X	X	X	X
Estonian		X	X		
Finnish	X	X	X		
French	X	X	X		X
Greek		X	X		
English	X	X	X	X	X
Italian	X	X	X		X
Croatian		X	X		
Latvian		X	X		
Lithuanian		X	X		
Dutch	X	X	X		
Polish	X	X	X		X
Portuguese	X	X	X		
Romanian	X	X	X		
Swedish	X	X	X		
Slovak		X	X		
Slovenian	X	X	X		
Spanish	X	X	X		X
Czech	X	X	X		X
Hungarian	X	X	X		
Europe (Non-EU)					
Macedonian		X	X		
Norwegian		X	X		
Russian	X	X	X		X
Serbian		X	X		
Turkish		X	X		
Asia					
Chinese (simplified)	X	X	X		X
Chinese (traditional)	X	X	X		X
Japanese		X	X		
Korean	X	X	X		X
Thai		x	X		
Middle East					
Arabian		X			
Persian		X			



Delivery program of applicators

HQ linerless applicators L



Pos.	Item no.	Designation	Item no.	Transfer modules	
4.1		5989285 Stroke applicator HQ 4024L-200 5989286 Stroke applicator HQ 4024L-300 5989287 Stroke applicator HQ 4024L-400 5989288 Stroke applicator HQ 4024L-600	5989301 Tamp-on pad, spring-mounted 4024-3000 105 x 100 5989302 Tamp-on pad, spring-mounted 4024-3000 105 x 150 5989303 Tamp-on pad, spring-mounted 4024-3000 105 x 210		
	upon request upon request upon request	Stroke applicator HQ 4026L-200 Stroke applicator HQ 4026L-300 Stroke applicator HQ 4026L-400 Stroke applicator HQ 4026L-600	upon request upon request upon request	Tamp-on pad, spring-mounted 4026-3000 150 x 100 Tamp-on pad, spring-mounted 4026-3000 150 x 150 Tamp-on pad, spring-mounted 4026-3000 150 x 210	
	4.3		5987520 Front side applicator HQ 3014L-200 5987521 Front side applicator HQ 3014L-300 5987522 Front side applicator HQ 3014L-400 5989343 Front side applicator HQ 3014L-600	xxxxxxx Tamp-on pad 3014L-1100 W x H xxxxxxx Tamp-on pad, spring-mounted 3014L-3100 W x H xxxxxxx Blow-on pad 3014L-2100 W x H	
		5987523 Front side applicator HQ 3016L-200 5987524 Front side applicator HQ 3016L-300 5987525 Front side applicator HQ 3016L-400 5989346 Front side applicator HQ 3016L-600	xxxxxxx Tamp-on pad 3016L-1100 W x H xxxxxxx Tamp-on pad, spring-mounted 3016L-3100 W x H		
		4.4		5987736 Stroke blow applicator HQ 4614L-200 5987738 Stroke blow applicator HQ 4614L-300 5987740 Stroke blow applicator HQ 4614L-400	xxxxxxx Blow-on pad 4614L-2100 W x H
4.5				5987534 Stroke applicator HQ 4014L-200 5987535 Stroke applicator HQ 4014L-300 5987536 Stroke applicator HQ 4014L-400 5987537 Stroke applicator HQ 4014L-600	5966147 Universal pad 4014L-1100 75 x 60 5966148 Universal pad 4014L-1100 90 x 90 5966149 Universal pad, spring-mounted 4014L-3100 116 x 102 5966150 Universal pad, spring-mounted 4014L-3100 116 x 152
			5987541 Stroke applicator HQ 4016L-200 5987542 Stroke applicator HQ 4016L-300 5987543 Stroke applicator HQ 4016L-400 5989344 Stroke applicator HQ 4016L-600	xxxxxxx Tamp-on pad 4014L-11 F W x H xxxxxxx Blow-on pad 4014L-2100 W x H xxxxxxx Tamp-on pad, spring-mounted 4014L-3100 W x H xxxxxxx Roll-on pad 4014L-4100 W x H xxxxxxx Corner-wrap pad 4014L-5100 W x H / H	
	5987714 Vacuum belt applicator 5414L-3 5989294 Vacuum belt applicator 5414L-4 5987718 Vacuum belt applicator 5416L-3 5987720 Vacuum belt applicator 5416L-4	xxxxxxx Tamp-on pad 4016L-11 F W x H xxxxxxx Tamp-on pad, spring-mounted 4016L-3100 W x H xxxxxxx Roll-on pad 4016L-4100 W x H			
	4.6		5972870 Vacuum belt applicator 5314L-2 5987552 Vacuum belt applicator 5314L-3 5989291 Vacuum belt applicator 5314L-4 5989292 Vacuum belt applicator 5316L-2 5987710 Vacuum belt applicator 5316L-3 5989293 Vacuum belt applicator 5316L-4		
		4.7		5987714 Vacuum belt applicator 5414L-3 5989294 Vacuum belt applicator 5414L-4 5987718 Vacuum belt applicator 5416L-3 5987720 Vacuum belt applicator 5416L-4	
4.8			5987564 Air jet box HQ 6114L 5 templates are included	5984709.001 Template 6114 L/R 5 items are included in a pack unit	

xxxxxxx - customer-specific part no. subsequent to request



HQ InNo-Liner applicators L

Pos.	Item no.	Designation	Item no.	Transfer modules
4.2		5989315 Stroke applicator HQ 4034L-200 5989316 Stroke applicator HQ 4034L-300 5989317 Stroke applicator HQ 4034L-400 upon request Stroke applicator HQ 4034L-600	5989384 Roll-on pad, spring-mounted 4034-4000 105 x 100 5989385 Roll-on pad, spring-mounted 4034-4000 105 x 150 5989376 Roll-on pad, spring-mounted 4034-4000 105 x 210	
	upon request upon request upon request	Stroke applicator HQ 4036L-200 Stroke applicator HQ 4036L-300 Stroke applicator HQ 4036L-400 Stroke applicator HQ 4036L-600	upon request upon request upon request	Roll-on pad, spring-mounted 4034-7000 105 x 100 Roll-on pad, spring-mounted 4034-7000 105 x 150 Roll-on pad, spring-mounted 4034-7000 105 x 210
	upon request upon request upon request	Stroke applicator HQ 4036L-200 Stroke applicator HQ 4036L-300 Stroke applicator HQ 4036L-400 Stroke applicator HQ 4036L-600	upon request upon request upon request	Roll-on pad, spring-mounted 4036-4000 150 x 100 Roll-on pad, spring-mounted 4036-4000 150x 150 Roll-on pad, spring-mounted 4036-4000 150 x 210
	upon request upon request	Stroke applicator HQ 4036L-200 Stroke applicator HQ 4036L-300	upon request upon request	Roll-on pad, spring-mounted 4036-7000 150 x 100 Roll-on pad, spring-mounted 4036-7000 150 x 150 Roll-on pad, spring-mounted 4036-7000 150 x 210
	4.9		5989380.001 Micro vaporizator 2L MSK 2L 5989312.001 Micro vaporizator 4L MSK 4L 5989382.001 Micro vaporizator 6L MSK 6L	

Applicator accessories







Pos.	Item no.	Designation
5.13		5964277.001 Blow tube 2" 5964095.001 Blow tube 4"
	5.14	
5.16		

Applicator options

Pos.	Item no.	Designation
5.17		596xxxx.212 Pressure-reducing valve xxxx - applicator item no.
	5.18	



Delivery program of applicators

HQ linerless applicators R

Pos.	Item no.	Designation	Item no.	Transfer modules			
4.1		5989295	Stroke applicator	HQ 4024R-200	5989301 5989302 5989303	Tamp-on pad, spring-mounted Tamp-on pad, spring-mounted Tamp-on pad, spring-mounted	4024-3000 105 x 100 4024-3000 105 x 150 4024-3000 105 x 210
		5989296	Stroke applicator	HQ 4024R-300			
		5989297	Stroke applicator	HQ 4024R-400			
		5989298	Stroke applicator	HQ 4024R-600	upon request upon request upon request upon request	Tamp-on pad, spring-mounted Tamp-on pad, spring-mounted Tamp-on pad, spring-mounted Tamp-on pad, spring-mounted	4026-3000 150 x 100 4026-3000 150 x 150 4026-3000 150 x 210
		upon request	Stroke applicator	HQ 4026R-200			
upon request	Stroke applicator	HQ 4026R-300					
upon request	Stroke applicator	HQ 4026R-400					
4.3		5987526	Front side applicator	HQ 3014R-200	xxxxxxx xxxxxxx xxxxxxx	Tamp-on pad Tamp-on pad, spring-mounted Blow-on pad	3014R-1100 W x H 3014R-3100 W x H 3014R-2100 W x H
5987527		Front side applicator	HQ 3014R-300				
5987528		Front side applicator	HQ 3014R-400				
5989354		Front side applicator	HQ 3014R-600	5987529 5987530 5987531 5989355	xxxxxxx xxxxxxx	Tamp-on pad Tamp-on pad, spring-mounted	3016R-1100 W x H 3016R-3100 W x H
5987529		Front side applicator	HQ 3016R-200				
5987530	Front side applicator	HQ 3016R-300					
5987531	Front side applicator	HQ 3016R-400					
5989355	Front side applicator	HQ 3016R-600					
4.4		5987742	Stroke blow applicator	HQ 4614R-200	xxxxxxx	Blow-on pad	4614R-2100 W x H
5987744		Stroke blow applicator	HQ 4614R-300				
5987746		Stroke blow applicator	HQ 4614R-400				
4.5		5987538	Stroke applicator	HQ 4014R-200	5966140 5966141 5966142 5966143	Universal pad Universal pad Universal pad, spring-mounted Universal pad, spring-mounted	4014R-1100 75 x 60 4014R-1100 90 x 90 4014R-3100 116 x 102 4014R-3100 116 x 152
		5987539	Stroke applicator	HQ 4014R-300			
		5987540	Stroke applicator	HQ 4014R-400			
		5989363	Stroke applicator	HQ 4014R-600			
		xxxxxxx			xxxxxxx xxxxxxx xxxxxxx xxxxxxx xxxxxxx	Tamp-on pad Blow-on pad Tamp-on pad, spring-mounted Roll-on pad Corner-wrap pad	4014R-11 F W x H 4014R-2100 W x H 4014R-3100 W x H 4014R-4100 W x H 4014R-5100 W x H / H
		5987545	Stroke applicator	HQ 4016R-200			
		5987546	Stroke applicator	HQ 4016R-300			
		5987547	Stroke applicator	HQ 4016R-400			
		5989356	Stroke applicator	HQ 4016R-600			
		xxxxxxx					
xxxxxxx			xxxxxxx	Roll-on pad	4016L-4100 W x H		
4.6		5987708	Vacuum belt applicator	5314R-2			
		5987556	Vacuum belt applicator	5314R-3			
		5989357	Vacuum belt applicator	5314R-4			
		5989358	Vacuum belt applicator	5316R-2			
		5987712	Vacuum belt applicator	5316R-3			
5989359	Vacuum belt applicator	5316R-4					
4.7		5987716	Vacuum belt applicator	5414R-3			
		5989360	Vacuum belt applicator	5414R-4			
		5987722	Vacuum belt applicator	5416R-3			
		5989361	Vacuum belt applicator	5416R-4			
4.8		5987565	Air jet box 5 templates are included	HQ 6114R	5984709.001	Template 5 items are included in a pack unit	6114 L/R

xxxxxxx - customer-specific part no. subsequent to request

HQ InNo-Liner applicators R

Pos.	Item no.	Designation	Item no.	Transfer modules			
4.2		5989325	Stroke applicator	HQ 4034R-200	5989384 5989385 5989376	Roll-on pad, spring-mounted Roll-on pad, spring-mounted Roll-on pad, spring-mounted	4034-4000 105 x 100 4034-4000 105 x 150 4034-4000 105 x 210
		5989326	Stroke applicator	HQ 4034R-300			
		5989327	Stroke applicator	HQ 4034R-400			
		upon request	Stroke applicator	HQ 4034R-600	upon request upon request upon request upon request	Roll-on pad, spring-mounted Roll-on pad, spring-mounted Roll-on pad, spring-mounted	4034-7000 105 x 100 4034-7000 105 x 150 4034-7000 105 x 210
		upon request	Stroke applicator	HQ 4036R-200			
		upon request	Stroke applicator	HQ 4036R-300			
		upon request	Stroke applicator	HQ 4036R-400			
		upon request	Stroke applicator	HQ 4036R-600	upon request upon request upon request	Roll-on pad, spring-mounted Roll-on pad, spring-mounted Roll-on pad, spring-mounted	4036-4000 150 x 100 4036-4000 150x 150 4036-4000 150 x 210
		upon request	Stroke applicator	HQ 4036R-200			
		upon request	Stroke applicator	HQ 4036R-300			
4.9		5989381.001	Micro vaporizator 2R	MSK 2R			4036-7000 150 x 100 4036-7000 150 x 150 4036-7000 150 x 210
		5989339.001	Micro vaporizator 4R	MSK 4R			
		5989383.001	Micro vaporizator 6R	MSK 6R			

Germany

cab Produkttechnik GmbH & Co KG

Karlsruhe

Phone +49 721 6626 0

www.cab.de

France

cab Technologies S.à.r.l.

Niedermodern

Phone +33 388 722501

www.cab.de/fr

USA

cab Technology, Inc.

Chelmsford, MA

Phone +1 978 250 8321

www.cab.de/us

Mexico

cab Technology, Inc.

Juárez

Phone +52 656 682 4301

www.cab.de/es

Taiwan

cab Technology Co., Ltd.

Taipei

Phone +886 (02) 8227 3966

www.cab.de/tw

China

cab (Shanghai) Trading Co., Ltd.

Shanghai

Phone +86 (021) 6236 3161

www.cab.de/cn

Singapore

cab Singapore Pte. Ltd.

Singapore

Phone +65 6931 9099

www.cab.de/en

South Africa

cab Technology (Pty) Ltd.

Randburg

Phone +27 11 886 3580

www.cab.de/za

cab // more than 500 distribution and service partners in more than 60 countries

