

# Mx350i-DTP

**Mx350i-DTP** is the perfect choice for printing labels when hand application is most convenient for your production line. Using the very same printer, it is easily integrated alongside other **Mx-Series** models as a complement or as a backup. Ideal for producing case, carton, tray or pallet labels, the **Mx350i-DTP** is reliable and robust with same connectivity options and easy-to-use interface as in the rest of the Domino Print & Apply range.



## Easy to integrate

- ◆ The **Mx-Series** advanced connectivity options allow for seamless integration with ERP, WMS, and MES systems in your factory.
- ◆ Seamless integration with all **Mx-Series** models used for automatic label application.

## Easy to use

- ◆ The user-friendly integrated UI and optional remote 10-inch touchscreen make the **Mx350i-DTP** very easy to operate.
- ◆ The robust design and clever functionality minimises the time needed for media changes and maintenance, so you can maximise your production uptime.

## Technical specification

Model	Mx350i-DTP4	Mx350i-DTP6
Print width	4-inch (108mm)	6-inch (162mm)
Print technology	Thermal transfer / Direct thermal	
Print resolution	12 dots/mm (300dpi)	
Printer variants	Left hand or Right hand	
Max print speed	400mm/s	250mm/s
Recommended label width	25-110mm	25-150mm
Recommended label length	15-600mm	
Label & ribbon roll length	Up to 600m	
Input voltage	90-250VAC 50/60Hz	
Communication	4x Ethernet, TCP/IP, 2x USB-A, 1x USB-B	
I/Os (configurable)	12 inputs and 12 outputs	

### Dimensions

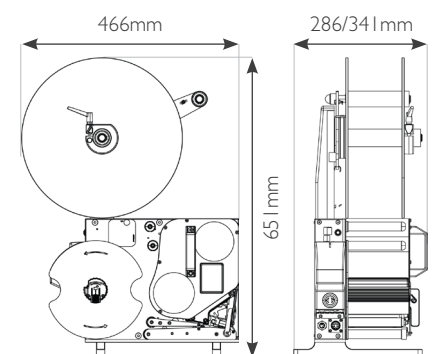

[www.domino-printing.com](http://www.domino-printing.com)